

Range: I19-035 Kompan Modular

Transparent panels allows interaction and communication with others on the ground.



3D net Fast and efficient access on one half and a challenging climb on the other, both supporting sense of space and muscle strength

Shoes and boots are safely stored in the integrated shoe rack.

The climbing rope challenge the children's cross-coordination skills as well as their physical strength.

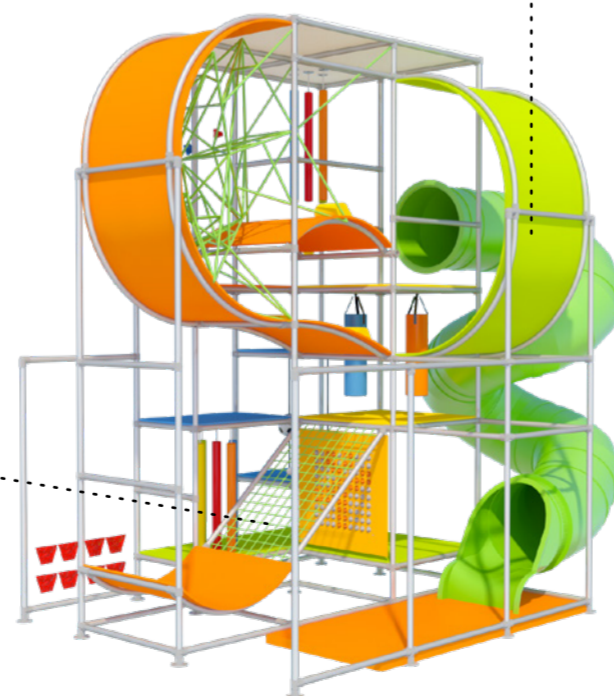

Sliding develops spatial awareness and sense of balance. Furthermore, the core muscles are trained when sitting upright going down.

Product information

Activities

- Shoe holders
- Hanging noodles
- Soccer balls
- Punching bags
- Ball wall
- Climbing rope
- Wave shaped floor
- Wave shaped climbing panel

- Pyramid
- Climbing grips
- 3D net
- Spiral slide
- Level changes
- Themed illustrations

Sizes

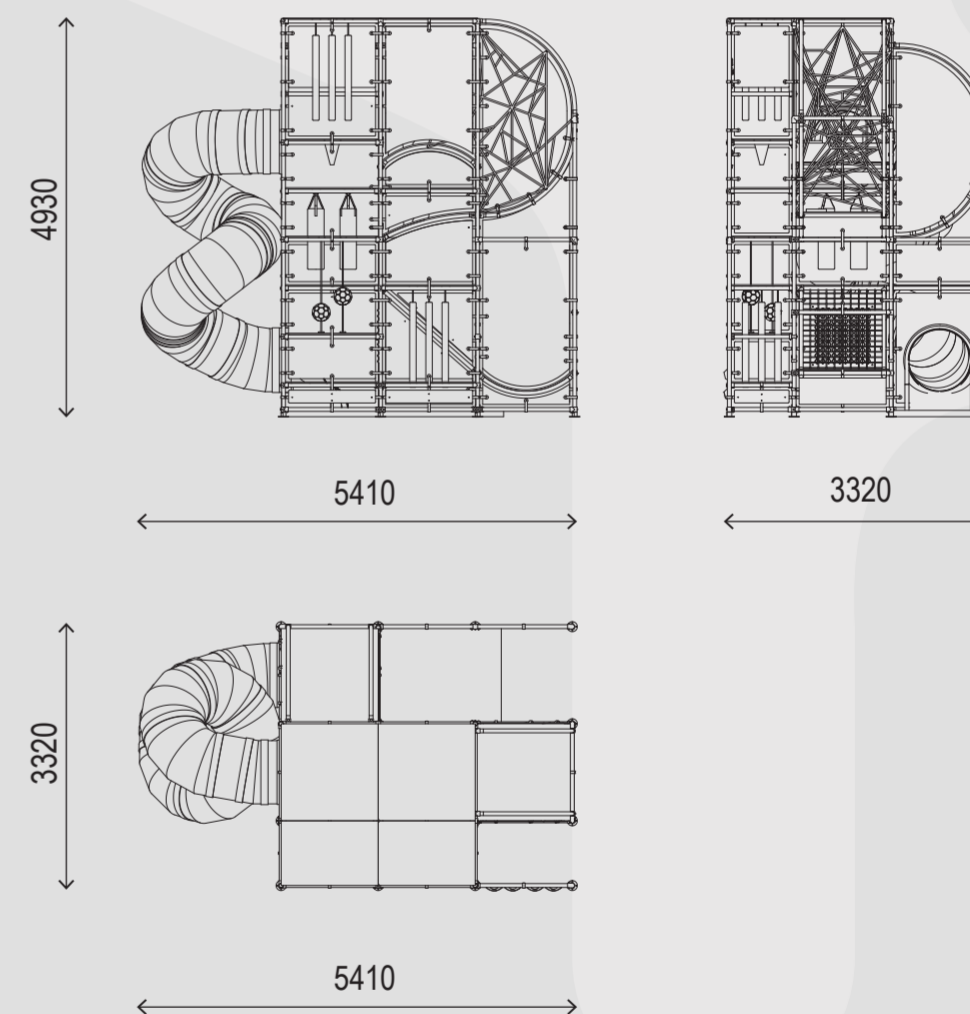

Age: 3-10

Capacity: 29 Children

By adding freestanding activities you increase the children capacity in the room.

